

# NINJA®

## MC950Z

Series

---

### OWNER'S GUIDE

## 4-in-1 COOKING SYSTEM



ninjakitchen.com

# IMPORTANT SAFEGUARDS

HOUSEHOLD USE ONLY • READ ALL INSTRUCTIONS BEFORE USE

WHEN USING ELECTRICAL APPLIANCES, BASIC SAFETY PRECAUTIONS SHOULD ALWAYS BE FOLLOWED, INCLUDING THE FOLLOWING:

READ ALL INSTRUCTIONS BEFORE USING YOUR NINJA® 4-in-1 COOKING SYSTEM.

## POLARIZED PLUG

**⚠️ WARNING:** To reduce the risk of electric shock, this appliance has a polarized plug (one blade is wider than the other). This plug will fit into a polarized outlet only one way. If the plug does not fit fully into the outlet, reverse the plug. If it still does not fit, contact a qualified electrician to install the proper outlet. **DO NOT** modify the plug in any way.

## ⚠️ WARNING: TO REDUCE THE RISK OF FIRE, ELECTRIC SHOCK OR INJURY:

- ⚠️ CAUTION:** TO REDUCE THE RISK OF ELECTRIC SHOCK, COOK ONLY IN THE POT PROVIDED OR IN A CONTAINER RECOMMENDED BY SHARKNINJA OPERATING LLC PLACED IN THE PROVIDED POT. **DO NOT USE THE APPLIANCE WITHOUT THE REMOVABLE COOKING POT INSIDE.**
- To protect against electrical shock, do not submerge the unit or allow the power cord to come into contact with water or any other liquid. If the unit falls into liquid, unplug the power cord from the electrical outlet immediately. **DO NOT** reach into the liquid.
- Please note that the appliance may become hot during use. **DO NOT** touch hot surfaces; always use the handles. Always use oven mitts or pot holders when removing the pot.
- DO NOT** allow young children to operate the appliance or use as a toy. Close supervision is necessary when any appliance is used near children.
- Remove the power cord from the electrical outlet when not in use, before assembling or disassembling parts and before cleaning. To unplug, grasp the plug and pull from the electrical outlet. Never pull from the power cord. Allow the appliance to cool before adding or removing parts.
- DO NOT** abuse the power cord. Never carry the appliance by the power cord or yank it to disconnect from electrical outlet; instead grasp the plug and pull to disconnect.
- DO NOT** operate any appliance with a damaged cord or plug, or after the appliance malfunctions, has been dropped or damaged in any manner. Return the appliance to SharkNinja Operating LLC for examination, repair or adjustment.
- Please refer to the Cleaning & Maintenance section for regular maintenance of the appliance. Return the appliance to SharkNinja Operating LLC for any other servicing.

- DO NOT** let the power cord touch hot surfaces such as the stove.
- Always use the appliance on a dry, level surface.
- Extreme caution must be used when moving an appliance containing hot oil or other hot liquids. Always use oven mitts or pot holders when moving the cooking system. Allow hot oil to cool prior to removal or cleaning the appliance.**
- To avoid possible steam damage, place the cooking system away from walls and cabinets during use.
- When using this appliance, provide adequate air space above and on all sides for air circulation. On surfaces where heat may cause a problem, use of an insulated heat pad or trivet is recommended.
- Use extreme caution when removing the lid after cooking. Serious burns can result from the steam inside. Always lift and tilt the lid away from you when removing, using care to ensure that water does not drip back into the appliance.**
- DO NOT** use outdoors or anywhere the cord or unit housing might come into contact with water while in use.
- DO NOT** use the appliance for anything other than its intended use.
- DO NOT** obstruct the steam release vent during use.
- Always position the steam vent hole in the back of the unit away from you.
- DO NOT** place or operate this appliance on or near any hot surfaces (such as gas or electric burner, stove or in a heated oven).
- The use of attachments or accessories not recommended by the manufacturer may result in fire, electric shock or personal injury.
- DO NOT** use this appliance for deep frying.
- To disconnect, turn the Function Dial to "Off", then remove the plug from the wall outlet.
- This appliance has a cut off switch which will not allow the appliance to heat if the cooking pot is not inserted into the housing or removed while cooking.
- DO NOT** use an extension cord. A short power-supply cord is used to reduce the risk resulting from it being grabbed by children, becoming entangled in, or tripping over a longer cord.
- To avoid the possibility of the cooking system accidentally being pulled off the counter top or tabletop, which could result in damage to the cooking system or personal injury, do not let the power cord hang over the edge of the counter or table.
- Leaving food out too long at room temperature can cause bacteria to grow to dangerous levels that can cause illnesses. In the event of a loss of power, an error message will display on the unit. It is recommended to dispose of any food that has been at room temperature for more than an hour.
- THIS PRODUCT IS INTENDED FOR HOUSEHOLD USE ONLY.** Do not use this appliance for anything other than its intended use. Do not use outdoors.

**READ AND SAVE THESE INSTRUCTIONS**

# THANK YOU

for purchasing the Ninja® 4-in-1 Cooking System



## REGISTER YOUR PURCHASE

 [registeryourninja.com](http://registeryourninja.com)

 Scan QR code using mobile device

## RECORD THIS INFORMATION

Model Number: \_\_\_\_\_

Serial Number: \_\_\_\_\_

Date of Purchase: \_\_\_\_\_  
(Keep receipt)

Store of Purchase: \_\_\_\_\_

## TECHNICAL SPECIFICATIONS

Voltage: 120V, 60Hz

Watts: 1200W

## THIS BOOK COVERS

### MODEL NUMBERS:

MC950Z

MC950CN

MC950SS

**TIP:** You can find the model and serial numbers on the QR code label located on the back of the unit by the power cord.

# CONTENTS

<b>Getting to Know Your Ninja® 4-in-1 Cooking System . . . . .</b>	<b>6</b>
<b>Getting to Know Your Ninja® 4-in-1 Cooking System Control Panel . . . . .</b>	<b>8</b>
<b>Preparing to Use the Ninja® 4-in-1 Cooking System . . . . .</b>	<b>8</b>
<b>Using the Different Functions . . . . .</b>	<b>9</b>
<b>Hints &amp; Tips . . . . .</b>	<b>12</b>
<b>Troubleshooting Guide . . . . .</b>	<b>12</b>
<b>Cleaning &amp; Maintenance . . . . .</b>	<b>13</b>
<b>Replacement Parts . . . . .</b>	<b>13</b>
<b>Warranty &amp; Registration . . . . .</b>	<b>15</b>

## GETTING TO KNOW YOUR NINJA® 4-IN-1 COOKING SYSTEM

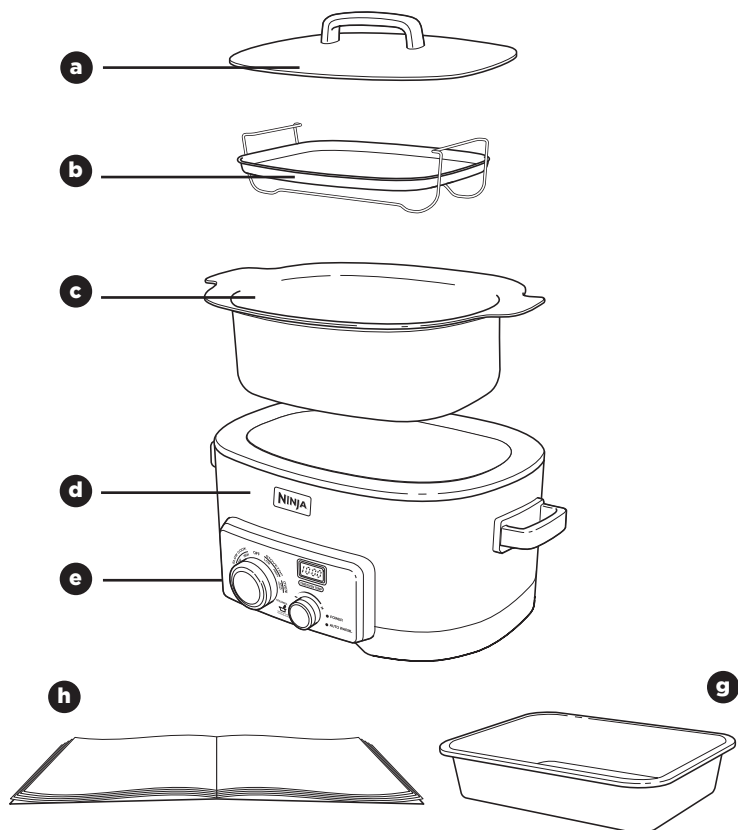

- |  |                            |
|--|----------------------------|
| <b>a</b> Glass Lid                           | <b>e</b> Control Panel     |
| <b>b</b> Roasting/Steaming Rack              | <b>g</b> Multi Purpose Pan |
| <b>c</b> Cooking Pot                         | <b>h</b> 150 Recipe Book   |
| <b>d</b> Main Housing (power cord not shown) |                            |

The **Ninja®** 4-in-1 Cooking System Steam Oven offers a revolutionary new way to cook your foods fast and easy. The easy 1-2-3 electronic controls allow you the flexibility for true one pot cooking.

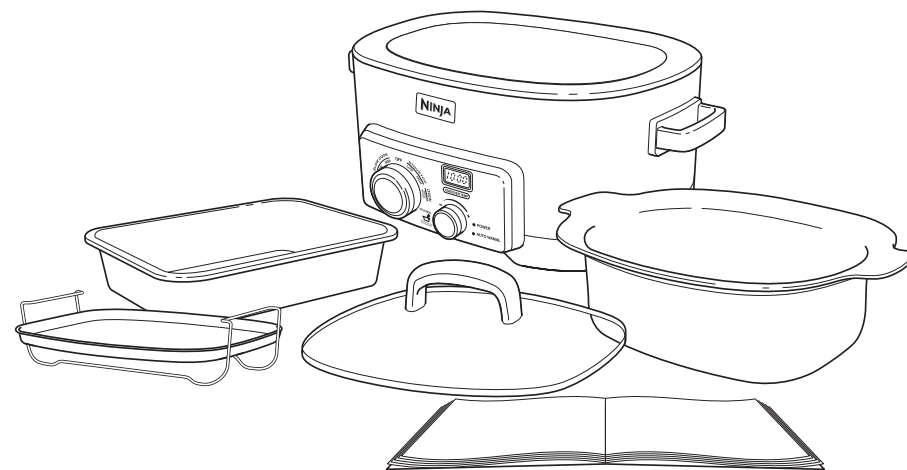

### FEATURES:

- Multi-Functional Cooking:
  - Slow Cooker: Warm, Low, High
  - Stove Top Cooker: Low, High
  - Oven: 250°F - 425°F
  - Steamer
- Auto Warm (Slow Cooker, Steamer)
- Digital time/temperature controls with beeping alert
- Stainless steel Roasting/Steaming Rack
- Auto Shutoff

# GETTING TO KNOW THE NINJA® 4-IN-1 COOKING SYSTEM CONTROL PANEL

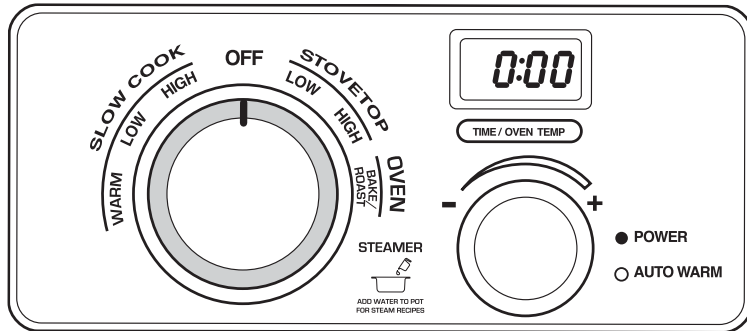

## FUNCTION DIAL

Turn the dial to select Slow Cook, Stovetop, Oven or Steamer mode.

**Slow Cook** - Use the Ninja® 4-in-1 Cooking System as a slow cooker. Select the temperature - Low or High and let the cooking system do all the work. When it has finished cooking, it will automatically switch to Auto Warm. Use the Warm mode for already cooked food to keep it warm for 30 minutes up to 12 hours.

**Stovetop** - Use the Ninja® 4-in-1 Cooking system as you would a stovetop. You can simmer (Low), or sear (High) your food.

**Oven** - Use the Ninja® 4-in-1 Cooking System instead of a regular oven. You can roast or bake and even add water to roast and bake with steam infusion.

**Steamer** - Use the Ninja® 4-in-1 Cooking System as a steamer. You can cook food on the Roasting/Steaming rack with the power of steam.

## LED Display Screen

The LED screen displays the timer settings for the Slow Cook, Warm, Oven, and Steamer modes. It also displays the temperature setting for the Oven mode.

## Adjustment Dial

Use the Adjustment dial to set the count down timer in Slow Cook, Oven, and Steamer mode, and set the temperature in Oven mode.

## Time/Oven Temp. Button

Use the Time/Oven Temp button to toggle between the Time and Temperature when using the Oven mode. Only applies to Oven mode.

## Auto Warm

The Ninja® 4-in-1 Cooking System will go into an auto warming mode when the set cooking time in Slow Cook and Steamer mode is over.

## PREPARING TO USE THE NINJA® 4-IN-1 COOKING SYSTEM

Before using the cooking system for the first time:

- Carefully remove all the parts from the box. Wash the cooking pot, glass lid, roasting/steaming rack, and multi-purpose pan with warm, soapy water. The cooking pot, roasting/steaming rack and lid may also be washed in the dishwasher. The multi-purpose pan is hand-washable. Do not place the main housing in water or in the dishwasher. Wipe it clean with a damp cloth.
- When ready to use, place the cooking pot inside the main housing. Never use the cooking system without the cooking pot inserted into the housing.

- Plug the unit into a wall outlet.
- The cooking system will not turn "ON" as long as the Function Dial is in the "OFF" position.
- When ready to start the appliance, turn the Function Dial to the function that you want. The red Power light will light up indicating that the appliance is on.
- Follow instructions on the following pages on how to use the different functions.

# USING THE DIFFERENT FUNCTIONS

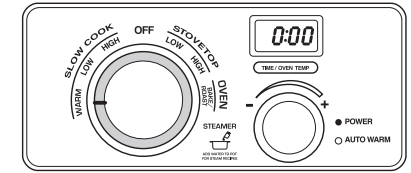
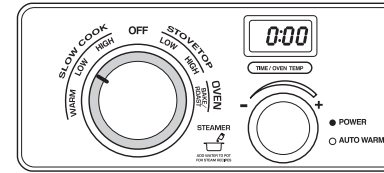

**WARNING:** Place the vent hole on the lid facing away from you.

**WARNING:** Use oven mitts when moving the unit, opening the lid, and when inserting or removing food.

## SLOW COOK

The 6 qt. capacity makes this an ideal slow cooker for the entire family. The Low and High settings automatically switch to Auto Warm after the cooking is complete to keep the food warm. Use the Stovetop function on "High" to sear meats and vegetables before slow cooking to enhance flavors and create gourmet meals.

Do not exceed the top of the cooking pot when filling with food. This could result in the food boiling over.

- Place the ingredients into the cooking pot and place the lid on top.
- Plug the unit into the electrical outlet.
- Turn the Function Dial to either Low or High under Slow Cook depending on the recipe instructions. The LED Display will show "8:00" or "4:00" depending on the slow cook setting that is selected and the Power Light will turn on.
- The Display Screen will show "8:00" hours for Low setting and "4:00" hours for High setting. Turn the Adjustment Dial to set the desired time. The time will increase or decrease in 30 minute increments for up to 12 hours. The timer will begin counting down after 3 seconds. Do not lift the lid continuously while cooking.
- After the cooking process is done, the unit will beep 3 times and then switch to Auto Warm for up to 12 hours.
- When you have finished using the unit, turn the Function Dial to "Off" and then unplug the unit and allow it to cool completely before handling.

## AUTO SHUT OFF FOR SLOW COOK

As a safety feature we have designed the unit to turn off automatically based on the setting that has been selected.

When in the Slow Cook "Low or High" modes, at the end of the cooking cycle the unit will automatically switch to Auto Warm for 12 hours. At the end of the 12 hours the unit will automatically shut off.

## SLOW COOK - WARM

Use the Ninja® 4-in-1 Cooking system Warm mode to keep food warm from 30 minutes up to 12 hours. This should only be used with food that was just cooked in the Slow Cooker mode, or with other food that has been prepared and still hot/warm.

- Place the cooked food inside the cooking pot and cover with the lid.
- Plug the unit into the electrical outlet.
- Turn the Function Dial to Warm.
- Time is pre-set to "6:00" hours. Turn the Adjustment Dial to set the desired time that you want the food kept warm.
- When you have finished using the unit, turn the Function Dial to "Off" and unplug the unit. Allow it to cool completely before handling.

## AUTO SHUT OFF FOR WARM

As a safety feature, we have designed the unit to turn off automatically based on the setting that has been selected. At the end of the pre-set time, the unit will automatically shut off.

## USING THE DIFFERENT FUNCTIONS - CONT.

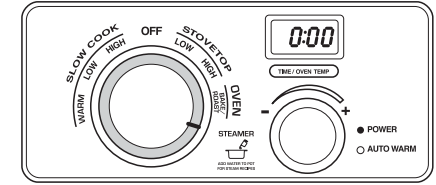
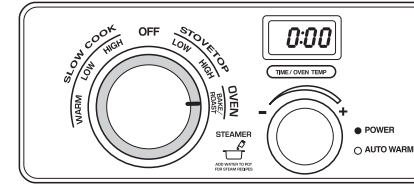
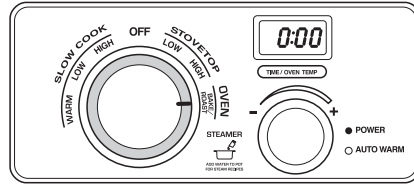
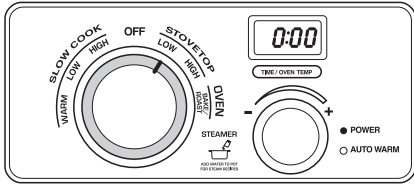

**⚠ WARNING:** Place the vent hole on the lid facing away from you.

**⚠ WARNING:** Use oven mitts when moving the unit, opening the lid, and when inserting or removing food.

**⚠ WARNING:** Place the vent hole on the lid facing away from you.

**⚠ WARNING:** Use oven mitts when moving the unit, opening the lid, and when inserting or removing food.

### STOVETOP

The Ninja 4-in-1 Cooking System lets you sear, brown, or sauté using the stovetop setting.

- 1 Place the cooking pot inside the housing.
- 2 Plug the unit into the electrical outlet.
- 3 Place the food that you wish to cook inside the pot in an even layer for best results.
- 4 Set the Function Dial to the desired Stovetop mode to get the appliance heated. The LED Display will show "On" and the Power light will turn on.
- 5 When you have finished using the unit, turn the Function Dial to "Off" and then unplug the unit and allow it to cool completely before handling.

**NOTE:** The appliance will not function if the cooking pot is not inside the main housing.

**TIP:** When you want to sear meats, set the Stovetop to "High".

To sauté vegetables, set the Stovetop to "High".

### AUTO SHUT OFF FOR STOVETOP

As a safety feature we have designed the unit to turn off automatically based on the setting that has been selected.

Stovetop High: Auto shut-off after 1 hour of use.

Stovetop Low: Auto shut off after 4 hours of use.

### OVEN

Variable temperatures from 250°F to 425°F make this an ideal oven for roasting meats and vegetables and for baking. The programmable timer can be set in 5 minute intervals for up to 6 hours.

### USING THE OVEN MODE FOR ROASTING

- 1 Place the food on the roasting/steaming rack and lower into the cooking pot. Cover with the lid.
- 2 Plug the unit into the electrical outlet.
- 3 Turn the Function Dial to Oven. The Power light will illuminate.
- 4 The Display Screen will show "350". Turn the Adjustment Dial to set the temperature. The temperature will adjust in 25° increments up to 425°F. Press the Time/Oven Temp button once and then turn the Adjustment Dial to set the cooking time. The time is pre-set at "1:00" hour and will increase in 5 minute increments up to a total of 6 hours.
- 5 The timer will begin counting down after 3 seconds. The time and temperature can be adjusted during the cooking cycle. Press the Time/Oven Temp button and then turn the Adjustment Dial to change the time or the temperature.
- 6 Once cooking is complete, the unit will beep 3 times and the time will blink for 2 minutes. At the end of the 2 minutes, the power will shut off.
- 7 When you have finished using the unit, turn the Function Dial to "Off", unplug the unit and allow it to cool completely before handling.

**TIP:** For best results, remove foods immediately after the cook time is complete to avoid overcooking.

**⚠ IMPORTANT:** Use caution when handling hot foods.

### OVEN

#### USING STEAM INFUSED COOKING

Steam Infused Cooking cooks foods fast all by the introduction of steam during the cooking process. The Steam Roasting technique can be applied to a variety of meats you would traditionally roast in your oven. Some cuts of meat benefit from searing **BEFORE** roasting while other cuts benefit from searing **AFTER** roasting, refer to the recipes in the included Inspiration Guide.

- No preheating is required when searing before roasting.
- Most meats can be seared for less than 10 minutes. You do not want to cook the meat, simply brown the meat to add color.
- Add water to the bottom of the cooking pot. In general, 1 cup of water equals 10 minutes of steam time.
- If additional water is required during the cooking process, cautiously lift the lid away from you and add room temperature water. Water should NOT exceed the roasting/steaming rack or touch the food as that will result in poaching.

**⚠** Use caution when placing hot meats on roasting/steaming rack.

**⚠ CAUTION: DO NOT** add any liquids to the base of the main housing of the appliance.

### STEAMER

Steam cooking is easy and fast when you use the **STEAMER** function for your favorite vegetables and light entrées. Refer to the included chart for recommended water and time settings.

- 1 Add water to pot according to recipe/chart and cover with the lid (1-4 cups).
- 2 Plug the unit into the electrical outlet
- 3 Turn Function dial to Steamer and set the time according to recipe/chart. Unit will beep and timer will show "P:" while preheating.
- 4 While the unit preheats, arrange the food onto the Roasting/Steaming Rack
- 5 When the water is fully boiling, the unit will beep and the timer will begin to count down.
- 6 **CAREFULLY** open the lid away from you, insert the rack with the food into the pot with mitts
- 7 Check food occasionally and remove food promptly when done to avoid overcooking.
- 8 When the timer reaches "0:00", the unit will go into Auto Warm mode.

**NOTE:** If water runs out before the timer shows "0:00", the unit will pause. If water is added, the unit will begin to bring it to a boil at which point the timer will continue where it left off.

## STEAMING CHART

VEGETABLES	SIZE/PREPARATION	COOKING TIME	LIQUID	SEASONING IDEAS
Artichokes	whole	25-40 minutes	4 cups	olive oil, lemon zest
Asparagus	whole spears	7-13 minutes	3 cups	olive oil
Beans, green	whole	6-10 minutes	2 cups	garlic, minced
Beans, wax	whole	6-10 minutes	2 cups	Italian seasoning
Beets	whole, unpeeled	35-50 minutes	4 cups	garlic, minced
Beet greens	coarsely chopped	7-9 minutes	2 cups	thyme
Broccoli	trimmed stalks	1-5 minutes	2 cups	olive oil
Broccoli	florets	5-7 minutes	2 cups	olive oil
Brussels sprouts	whole, trimmed	8-15 minutes	3 cups	thyme
Cabbage	cut in wedges	6-10 minutes	2 cups	lemon juice
Carrots	¼ inch slices	7-10 minutes	2 cups	maple syrup
Carrots, baby	whole	7-10 minutes	2 cups	honey & ginger
Cauliflower	florets	5-10 minutes	2 cups	lemon juice
Celery stalks	½ inch slices	5-7 minutes	2 cups	sesame seeds
Corn on the cob	whole, husks removed	4-7 minutes	2 cups	garlic butter
Kale	trimmed	5-8 minutes	2 cups	olive oil & garlic
Leeks	trimmed, cut in half	5-8 minutes	2 cups	vinaigrette
Okra	whole, trimmed	6-8 minutes	2 cups	sautéed scallions
Onions, pearl	whole	8-12 minutes	2 cups	lemon juice
Parsnips	peeled, ½ inch slices	7-10 minutes	2 cups	Italian seasoning
Peas, green	fresh or frozen shelled	2-4 minutes	2 cups	mint & lemon juice
Peas, sugar snap	whole pods, trimmed	5-6 minutes	2 cups	mint & lemon juice
Potatoes, all	½ inch slices	8-12 minutes	2 cups	parsley dill
Potatoes, new	whole	15-20 minutes	4 cups	parsley or rosemary
Potatoes, sweet	½ inch chunks	8-12 minutes	3 cups	honey
Scallions	½ inch slices	3-5 minutes	2 cups	olive oil & lemon zest
Spinach	whole leaves	3-5 minutes	2 cups	olive oil & garlic
Squash, butternut	peeled, ½ inch cubes	7-10 minutes	2 cups	maple syrup
Turnips	½ inch slices	8-12 minutes	3 cups	Italian seasoning
Turnip greens	coarsely chopped	4-8 minutes	2 cups	olive oil & garlic
Swiss Chard	coarsely chopped	3-5 minutes	2 cups	olive oil & garlic
Zucchini	1 inch slices	5-8 minutes	2 cups	olive oil & Italian seasoning

## HINTS & TIPS

- Cooking times may vary based on the selected temperature, the current temperature of the cooking pot and the temperature of the ingredients.
- Always use nonstick utensils in the cooking pot. Metal utensils may damage the non-stick coating.
- For even browning, make sure that the food is in an even layer on the bottom of the cooking pot or roasting/steaming rack.
- Cooking time and temperature can be adjusted at any time during the cooking cycle in Slow Cook and Oven. Press the Time/Oven Temp button and turn the Adjustment Dial to adjust.
- Cooked foods may not brown or crisp on top as much as in a conventional oven. Instead foods will brown on the bottom and crisp on the bottom and sides.
- If you do not manually set a temperature and time, the unit will automatically start at the preset temperature and time.
- Multiple modes may be required to cook recipes. To change modes during cooking cycles, simply turn the Function Dial to select the new desired mode. Once the new mode is selected, begin the programming process.
- If the cooking pot is removed during the cooking cycle and then placed back into the unit, the cooking process will continue as though it was not interrupted.
- For best results, remove foods immediately after the cook time is complete to avoid overcooking.
- Use oven mitts or tongs when removing food. The pot is HOT.**
- For smaller foods that might not sit evenly on the rack, we recommend steaming in a parchment or foil pouch.  
**NOTE:** If using foil, increase cooking time by 50% of what is recommended.
- When adding heavier foods like corn on the cob to the steaming rack, place them on the middle of the rack and work your way to the edges.
- When steaming delicate food like dumplings or tamales, it is best to add ingredients before preheating.
- Always use caution when removing lid.** It is best to remove the lid tilting away from you.

## TROUBLESHOOTING GUIDE

PROBLEM	POSSIBLE SOLUTION
"Err" Appears on the Display Screen	This occurs when power to the unit is interrupted or if the unit is plugged in and the function dial is not in the "OFF" position. Turn the function dial to "OFF" and then turn dial to desired cooking mode. If the unit displays "Err" for a prolonged period of time due to power failure, dispose of the food for health and safety reasons. Please contact customer service at 1-877-646-5288.
"E01" Appears on the Display Screen	Cooking pot is not inside the cooking system housing. Insert the cooking pot.
"E02" or "E03" Appears On The LED Display	Ninja® 4-in-1 Cooking System is not functioning. Please contact customer service at 1-877-646-5288.



## CLEANING & MAINTENANCE

---

The **Ninja**® 4-in-1 Cooking System should be cleaned thoroughly after every use.

- 1 Unplug the unit from the wall outlet.
- 2 Never immerse the main housing in water or any other liquid.
- 3 To clean the main housing and the control panel, wipe it clean with a damp cloth.
- 4 The multi-purpose pan is not dishwasher safe. Wash with warm, soapy water. The cooking pot, roasting/steaming rack and glass lid can be washed in the dishwasher.
- 5 Dry all parts after each use.
- 6 If food residue is stuck onto the cooking pot, fill the pot with water and allow to soak before cleaning. **DO NOT** use scouring pads. If scouring is necessary, use a non-abrasive cleanser or liquid detergent with a nylon pad or brush.
- 7 Please return the unit to SharkNinja Operating LLC for any other servicing.

**NOTE:** After usage, the exterior of the cooking pot may produce a black film when cleaned. This is due to oxidation and occurs from normal usage.

## REPLACEMENT PARTS

---

To order additional parts and accessories, please visit our website: [ninjaaccessories.com](http://ninjaaccessories.com) or feel free to contact customer service: **1-877-646-5288**.

## PRODUCT REGISTRATION

---

Please visit [registeryourninja.com](http://registeryourninja.com) or call **1-877-646-5288** to register your new Ninja® product within ten (10) days of purchase. You will be asked to provide the store name, date of purchase, and model number along with your name and address.

The registration will enable us to contact you in the unlikely event of a product safety notification. By registering, you acknowledge you have read and understood the instructions for use and warnings set forth in the accompanying instructions.

## Shark | NINJA ONE (1) YEAR LIMITED WARRANTY

---

The 1-Year Limited Warranty applies to purchases made from authorized retailers of SharkNinja Operating LLC. Warranty coverage applies to the original owner and to the original product only and is not transferable.

SharkNinja warrants that the unit shall be free from defects in material and workmanship for a period of 1 year from the date of purchase when it is used under normal household conditions and maintained according to the requirements outlined in this instruction manual, subject to the following conditions and exclusions.

### What is covered by my warranty?

1. The original unit and/or non-wearable components deemed defective, in SharkNinja's sole discretion, will be repaired or replaced for up to 1 year from the original purchase date.
2. In the rare event that a replacement unit is issued, the warranty coverage ends 6 months after the receipt date of the replacement unit or the remainder of the existing warranty, whichever is greater. If the unit is replaced, SharkNinja reserves the right to replace the unit with one of equal or greater value.

### What is not covered by my warranty?

Our Customer Service and Product Specialists are available to provide all the warranty service options available to you, including the possibility of upgrading to our VIP Warranty Service Options for select product categories.

1. Normal wear and tear of wearable parts (including removable pot, silicone ring, lids, racks, and baskets.) that require regular maintenance and/or replacement to ensure the proper functioning of your unit, are not covered by your warranty.
2. Any unit that has been tampered with or used for commercial purposes.
3. SharkNinja will cover the cost for the customer to send the unit to us for repair or replacement. A fee of \$19.95 for return shipping costs will be charged at the time of return shipment of the repaired or replacement unit.
4. Damage caused by misuse, abuse, or negligent handling, or damage due to mishandling in transit.
5. Consequential and incidental damages.
6. Defects caused by or resulting from damages from shipping or from repairs, service, or alteration to the product or any of its parts that have been performed by a repair person not authorized by SharkNinja.
7. Products purchased, used, or operated outside of North America.

### Problems with your unit/How to get service:

If your appliance fails to operate properly while in use under normal household conditions within the warranty period, visit [ninjakitchen.com](http://ninjakitchen.com) for product care/maintenance self-help. Our Customer Service and Product Specialists are also available at 1-877-646-5288 to assist with product support and warranty service options.

### How to initiate a warranty claim:

You can call 1-877-646-5288 to have a Customer Service Specialist assist you. Please note, you must call 1-877-646-5288 to initiate a warranty claim. Return and packing instruction information will be provided at that time.

For Customer Service hours, visit [ninjakitchen.com](http://ninjakitchen.com).

Replacement parts are available for purchase at [ninjaaccessories.com](http://ninjaaccessories.com). For more information on what are classified as wearable and non-wearable parts, visit [ninjakitchen.com/warranty](http://ninjakitchen.com/warranty).

This warranty gives you specific legal rights, and you may also have other rights that vary from state to state.

Some states do not permit the exclusion or limitation of incidental or consequential damages, so the above may not apply to you.





**SharkNinja Operating LLC**  
**US: Needham, MA 02494**  
**1-877-646-5288**  
**ninjakitchen.com**

Illustrations may differ from actual product. We are constantly striving to improve our products, therefore the specifications contained herein are subject to change without notice.

NINJA is a registered trademark of SharkNinja Operating LLC.

For SharkNinja U.S. Patent information, visit [sharkninja.com/uspatents](http://sharkninja.com/uspatents)

© 2019 SharkNinja Operating LLC

MC950ZSeries\_15\_IB\_EN\_Mv3

PRINTED IN CHINA



**@sharkcleaning**