

# NINJA®

STORM™

QB751Q Series

OWNER'S GUIDE



[ninjakitchen.com](http://ninjakitchen.com)

1 877 646-5288

# IMPORTANT SAFETY INSTRUCTIONS

## For Household Use Only

WHEN USING ELECTRICAL APPLIANCES, BASIC SAFETY PRECAUTIONS SHOULD ALWAYS BE FOLLOWED, INCLUDING THE FOLLOWING:

READ ALL INSTRUCTIONS BEFORE USING YOUR NINJA® STORM™.

### POLARIZED PLUG

**WARNING:** To reduce the risk of electric shock, this appliance has a polarized plug (one blade is wider than the other). This plug will fit into a polarized outlet only one way. If the plug does not fit fully into the outlet, reverse the plug. If it still does not fit, contact a qualified electrician to install the proper outlet. **DO NOT modify the plug in any way.**

**⚠ WARNING:** Extension cords are not recommended for use with this product.

**⚠ WARNING:**  
TO REDUCE THE RISK OF FIRE, ELECTRIC SHOCK OR INJURY:

- 1 **⚠ WARNING:** Remove utensils prior to processing. Failure to remove may cause the jar to be damaged or to shatter which may cause personal injury.
- 2 **⚠ WARNING:** 4-Blade Assembly is sharp, not locked in place and removable, handle with care. When handling the 4-Blade Assembly, always hold it by the shaft. Failure to do so will result in a risk of laceration.
- 3 **⚠ WARNING:** 4-Blade Assembly is sharp and not locked in place. Remove the splashguard and carefully remove the 4-Blade Assembly first, holding it by the shaft before pouring. Failure to do so will result in a risk of laceration.
- 4 **⚠ WARNING:** 4-Blade Assembly is sharp and not locked in place. If using the pour spout, ensure that the splashguard is fully on the pitcher. Failure to do so will result in a risk of laceration.
- 5 **⚠ CAUTION:** If pouring with the lid or splashguard removed, ALWAYS remove the 4-Blade Assembly first. Failure to do so will result in a risk of laceration.
- 6 **⚠ CAUTION:** Do not blend hot liquids, doing so may cause excessive pressure build-up, resulting in risk of the user being burned.
- 7 To protect against electrical shock, do not submerge the appliance or allow the power cord to come into contact with water or any other liquid.
- 8 **DO NOT** allow the appliance to be used by children. Close attention is necessary when used near children. This is not a toy.

- 9 Never leave an appliance unattended when in use.
- 10 Appliance accessories are not intended to be used in the microwave as it may result in damage to the accessories.
- 11 Remove the Master Pod from the appliance and unplug the power cord from the electrical outlet when not in use, before assembling or disassembling parts and before cleaning. To unplug, grasp the plug and pull from the electrical outlet. Never pull from the power cord.
- 12 **DO NOT** abuse the power cord. Never carry the Master Pod by the power cord or yank it to disconnect from electrical outlet; instead grasp the plug and pull to disconnect.
- 13 **DO NOT** operate any appliance with a damaged cord or plug, or after the appliance malfunctions, has been dropped or damaged in any manner. This appliance has no serviceable parts. Return the appliance to SharkNinja Operating LLC for examination, repair or adjustment.
- 14 **DO NOT** let the power cord hang over the edge of table or counter or touch hot surfaces such as the stove.
- 15 Always use appliance on a dry, level surface.
- 16 Keep hands, hair, clothing, as well as utensils out of container while processing to reduce the risk of severe injury to persons or damage to the appliance. A scraper may be used but only when the appliance is not running.
- 17 Avoid contact with moving parts.
- 18 **DO NOT** attempt to sharpen blades.
- 19 **DO NOT** use the appliance if blade assemblies are bent or damaged.
- 20 **DO NOT** expose pitcher to extreme temperature changes.
- 21 **DO NOT** use pitcher if it is cracked or chipped.
- 22 To reduce the risk of injury, **NEVER** operate the appliance without the splashguard in place; **DO NOT** try to defeat the interlock mechanism; make sure that the cutting blades are properly assembled before operating the appliance.
- 23 **DO NOT** operate this appliance on or near any hot surfaces (such as gas or electric burner or in a heated oven).
- 24 The use of accessory attachments, including canning jars not recommended by the manufacturer may cause fire, electrical shock or risk of personal injury.
- 25 **DO NOT** remove the Master Pod before the Ninja 4-Blades Assembly has stopped turning.
- 26 **DO NOT** overfill.
- 27 **DO NOT** operate the appliance empty.
- 28 **DO NOT** try to defeat the interlock mechanism. Make sure that the 40 oz. 4-Blade Assembly is properly inserted before operating the appliance.
- 29 Immediately release the On/Off pulse button on the Master Pod in the event that the appliance malfunctions during use.
- 30 **DO NOT** operate the appliance for more than 15 seconds.
- 31 **THIS PRODUCT IS INTENDED FOR HOUSEHOLD USE ONLY.** Do not use this appliance for anything other than its intended use. Do not use outdoors.
- 32 If the appliance overheats, a thermal switch will become activated and shut off the motor. To reset, unplug the appliance and let it cool down for approximately 10 minutes before using again.

# SAVE THESE INSTRUCTIONS

**THIS MANUAL COVERS MODELS:**

QB751QBK 30  
QB751QR 30  
QB751QPR 30  
QB751QBL 30  
QB751QY 30  
QB751QO 30  
QB751QL 30  
QB751QTQ 30  
QB751QPK 30  
QB751QE 30  
QB751QCN 30

**TECHNICAL SPECIFICATIONS**

Voltage: 120V., 60Hz.  
Power: 450 Watts  
Pitcher Capacity: 40 oz. (5 cups, 1.25 L)



# Contents

**Thank you for  
purchasing the  
Ninja® Storm™.**

Getting Started .....	5
Before First Use .....	7
Assembly and Use of the Pitcher .....	7
Cleaning and Maintenance .....	9
Troubleshooting Guide.....	9
Warranty .....	10

## Getting Started

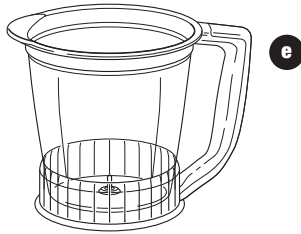
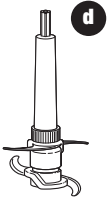
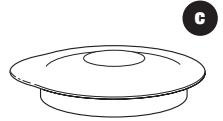
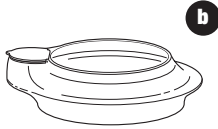
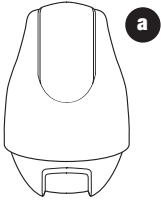

- a** Master Pod
- b** Splashguard
- c** Pitcher Storage Lid

- d** 40 oz. 4-Blade Assembly
- e** 40 oz. Pitcher with Non-Slip Base
- f** Power Cord (not shown)

The Ninja® Storm™ is an indispensable kitchen tool that is perfect for blending, whipping, ice crushing and food processing - all in the conveniently sized pitcher! For best results, be sure to carefully read all the instructions contained in the manual before using this appliance.

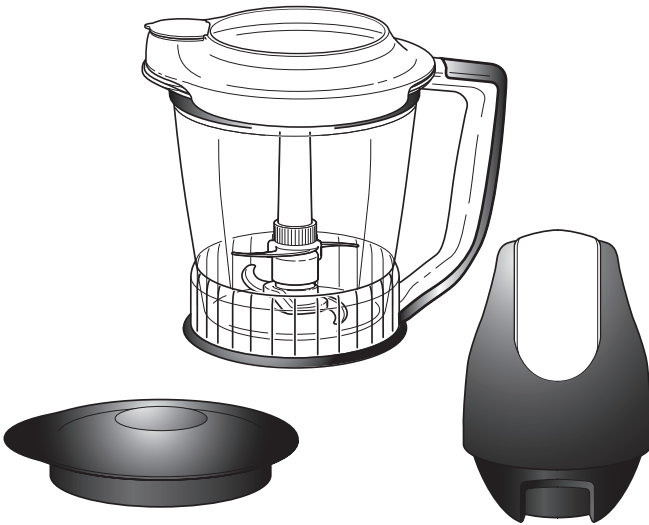

## Before First Use

**⚠ WARNING: 40 oz. 4-Blade Assembly is sharp and not locked in place. If using the pour spout, ensure that the splashguard is fully on the pitcher. Failure to do so will result in a risk of laceration.**

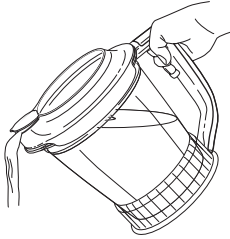

## Assembly and Use of the Pitcher

**⚠ CAUTION: If pouring with the lid or splashguard removed, ALWAYS remove the 40 oz. 4-Blade Assembly first. Failure to do so will result in a risk of laceration.**

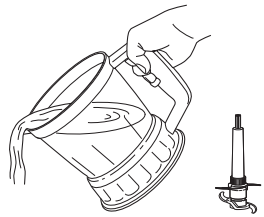

### PLEASE KEEP THESE IMPORTANT SAFEGUARDS IN MIND WHEN USING THE APPLIANCE:

**IMPORTANT:** Make sure that the Master Pod is plugged in for use.

**IMPORTANT:** Never add ingredients into the container before placing the 40 oz. 4-Blade Assembly in first.

**IMPORTANT:** Attachments are not interchangeable.

**IMPORTANT:** DO NOT attempt to operate the appliance without the splashguard on.

**IMPORTANT:** Never run the appliance empty.

**IMPORTANT:** Appliance accessories are not intended to be used in the microwave as it may result in damage to the accessories.

**⚠ CAUTION: Do not immerse the Master Pod into water or any other liquid.**

1 Remove all packaging material and labels from the appliance. Separate/remove all parts from each other.

2 Wash the lid, splashguard, pitcher, and 40 oz. 4-Blade Assembly in warm, soapy water. When washing the blade assembly, use a dish-washing utensil with a handle to avoid direct hand contact with blades.

**⚠ WARNING: Handle the 40 oz. 4-Blade Assembly with care when washing, as the blades are sharp.**

3 Handle the 40 oz. 4-Blade Assembly with care to avoid contact with sharp edges. Rinse and air dry thoroughly.

4 The pitcher, lid, splashguard, and 40 oz. 4-Blade Assembly are all dishwasher safe. It is recommended that the lid, splashguard and blade assembly be placed on the top rack. Ensure that the blade assembly is removed from the pitcher before placing in the dishwasher.

5 Wipe the motor base clean with a damp cloth.

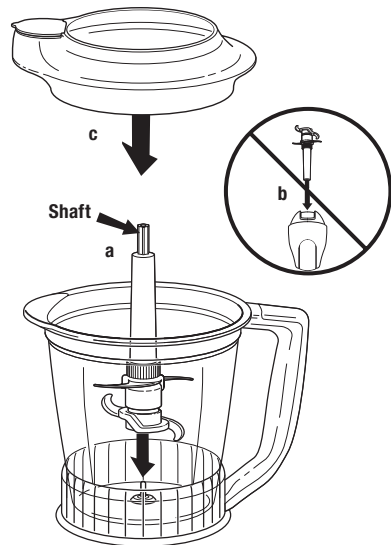

Fig. 1

1 Review warning and caution statements at the top of page 8 before proceeding to number 2.

2 Place the pitcher on a clean, dry, level surface.

3 Add the ingredients to be processed into the pitcher.

4 Holding the 40 oz. 4-Blade Assembly by the shaft, place it onto the spindle pin inside the pitcher. (Fig. 1, a)

**⚠ WARNING: Place 40 oz. 4-Blade Assembly inside the pitcher carefully as blades are sharp.**

**⚠ WARNING: DO NOT try to place the 40 oz. 4-Blade Assembly onto the Master Pod and then into the pitcher. (Fig. 1, b)**

**IMPORTANT:** Never add ingredients into the pitcher before placing the blades in first.

5 Place the pitcher splashguard onto the top of the pitcher. (Fig. 1, c)



- ⚠ **WARNING:** Handle the 40 oz. 4-Blade Assembly with care, as the blades are sharp.
  - ⚠ **WARNING:** Remove utensils prior to processing. Failure to remove may cause the pitcher to be damaged or to shatter, which may cause personal injury.
  - ⚠ **WARNING:** DO NOT try to place the 40 oz. 4-Blade Assembly onto the Master Pod and then into the pitcher.
  - ⚠ **WARNING:** DO NOT attempt to operate the appliance without the safety splashguard in place.
  - ⚠ **WARNING:** Never leave the appliance unattended while in use.
  - ⚠ **CAUTION:** Do not blend hot liquids, doing so may cause excessive pressure buildup, resulting in risk of the user being burned.
- IMPORTANT:** Make sure that the Master Pod is plugged in for use.

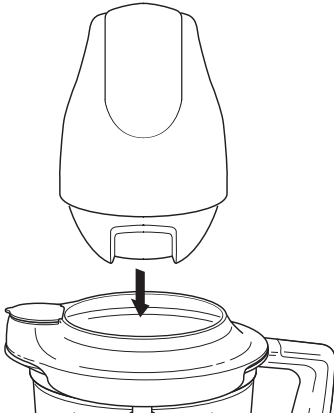

Fig. 2

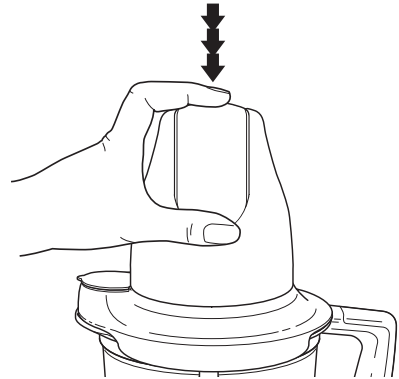

Fig. 3

- 6 Place the Master Pod on top of the splashguard making sure that it is securely in place. **(Fig. 2)**
- 7 To start the appliance, plug the power cord into the electrical outlet, securely hold the Master Pod while operating and press on the On/Off pulse button located on the top of the Master Pod. **(Fig. 3)**
- 8 Hold the pitcher firmly while depressing the On/Off pulse button to ensure the unit stays in place.  
**NOTE: DO NOT** operate the appliance continuously for more than 15 seconds at a time.
- 9 To stop the appliance, remove your fingers from the On/Off pulse button.
- 10 In order to obtain a better quality of chopping, operate the appliance by using the "pulse" method.
- 11 Make sure that the 40 oz. 4-Blade Assembly has stopped completely before removing the Master Pod.
- 12 If the ingredients stick to the side of the pitcher, stop the appliance, remove the Master Pod and the splashguard. Use a spatula to dislodge the pieces and then replace the splashguard and the Master Pod. Continue processing.

- 13 Depending on the consistency of the contents, use the pour spout to empty liquid contents.
- 14 For thicker consistencies, first remove splashguard and 40 oz. 4-Blade Assembly (by its shaft), then empty contents of the pitcher.

**HINTS & TIPS FOR USING YOUR NINJA®**

- The 40 oz. 4-Blade Assembly can be used for chopping meat, fish, vegetables, cheese etc.
- For mincing, chopping and pureeing, increase the length of pulses.
- For coarse chopping, use short, quick pulses and monitor food texture.
- Pre-cut larger pieces to make them fit into the pitcher. When chopping hard foods (e.g. meat, cheese) cut into 1-inch cubes.
- To crush ice into snow, start by using short pulses to break up large chunks. Continue until snow is achieved.

# Cleaning and Maintenance

## HOW TO CLEAN

- ▲ CAUTION:** Remove the Master Pod from the appliance and unplug the power cord from the electrical outlet before assembling or disassembling parts and before cleaning.
- ▲ CAUTION: DO NOT** immerse the Master Pod into water or any other liquid. Clean with a damp sponge or cloth and wipe dry.
- 1 Separate/remove all parts from each other.
- 2 Hand Washing: Wash the lid, splashguard, pitcher, and Ninja 4-Blade assembly in warm, soapy water. When washing the 40 oz. 4-Blade Assembly, use a dish-washing utensil with a handle to avoid direct hand contact with blades. Handle the 40 oz. 4-Blade Assembly with care to avoid contact with sharp edges. Rinse and air dry thoroughly.
- ▲ WARNING: Handle the 40 oz. 4-Blade Assembly with care when washing, as the blades are sharp. Contact with the blades' edges can result in laceration.**
- 3 Dishwasher: The pitcher, lid,, splashguard, and 40 oz. 4-Blade Assembly are all dishwasher safe. It is recommended that the lid and blade assembly be placed on the top rack. Ensure the blade assembly is removed from the pitcher before placing in the dishwasher.
- 4 Wipe the motor base clean with a damp cloth.  
Please call customer service if any servicing needs to be performed on the appliance at 1-877-646-5288.

## HOW TO STORE

- 1 Store the Ninja® Storm™ upright with the 40 oz. 4-Blade Assembly inside the pitcher and splashguard and Master Pod on the pitcher. Do not place anything on top. Store the rest of the attachments along side the appliance or in a cabinet where they will not be damaged and won't cause a hazard. Loosely wrap the power cord around the Master Pod.

## Troubleshooting Guide

PROBLEMS	POSSIBLE REASONS & SOLUTIONS
<b>Motor Doesn't Start or Blades Don't Rotate.</b>	<p>Check that the bottom of motor head is clean and there is no food blocking connection when placing on containers.</p> <p>There is too much food in the pitcher.</p> <p>The unit has overheated. Unplug and wait approximately 10 minutes before using again.</p> <p>Make sure the splashguard is securely on pitcher.</p> <p>Make sure the Master Pod is securely placed on splashguard.</p> <p>Check that the plug is securely inserted into the electrical outlet.</p> <p>Check fuse or breaker. Replace fuse/reset breaker.</p>
<b>Food is Unevenly Chopped.</b>	<p>Either you are chopping too much food at one time, or the pieces are not small enough. Try cutting the food into smaller pieces of even size and processing smaller amounts per batch.</p>
<b>Food is Chopped Too Fine or is Too Watery.</b>	<p>The food has been over processed. Use brief pulses or process for shorter time. Let blades stop completely between pulses.</p>
<b>Food Collects On Splashguard/ Safety Cover or On the Sides of the pitcher.</b>	<p>You may be processing too much food. Turn the machine Off. When the blades stop rotating, remove the Master Pod and the splashguard. Remove some of the food being processed.</p>
<b>You Cannot Achieve Snow From Solid Ice.</b>	<p>Do not use ice that has been sitting out or has started to melt. Be sure to use short pulses in the beginning to break up large pieces.</p>

# Shark | NINJA

## ONE (1) YEAR LIMITED WARRANTY

**SharkNinja Operating LLC** warrants this product to be free from material defects and workmanship for a period of one (1) year from the date of purchase when utilized for normal household use, subject to the following conditions, exclusions and exceptions.

The liability of **SharkNinja Operating LLC** is limited solely to the cost of the repair or replacement of the unit at our option. This Limited Warranty does not cover normal wear of parts and does not apply to any unit that has been tampered with or used for commercial purposes. This Limited Warranty does not cover damage caused by misuse, abuse, negligent handling or damage due to faulty packaging or mishandling in transit. This Limited Warranty does not cover damage or defects caused by or resulting from damages from shipping or repairs, service or alteration to the product or any of its parts, which have been performed by a repair person not authorized by **SharkNinja Operating LLC**.

If your appliance fails to operate properly while in use under normal household conditions within the Limited Warranty period, you may return the complete appliance and accessories with proof of purchase and date, freight prepaid. For Customer Service support, call 1-877-646-5288 or visit our website [www.ninjakitchen.com](http://www.ninjakitchen.com).

If the appliance is found by **SharkNinja Operating LLC** to be defective, in **SharkNinja Operating LLC's** sole discretion, we will repair or replace it free of charge. Proof of purchase date and a check made payable to **SharkNinja Operating LLC** in the amount of \$19.95 to cover the cost of return shipping and handling must be included.\*

This Limited Warranty is extended to the original purchaser of the unit and excludes all other legal, implied and/or conventional warranties. The responsibility of **SharkNinja Operating LLC** if any, is limited to the specific obligations expressly assumed by it under the terms of this Limited Warranty. **In no event is SharkNinja Operating LLC** liable for incidental or consequential damages to anyone of any nature whatsoever. Some states do not permit the exclusion or limitation of incidental or consequential damages, so the above may not apply to you.

This Limited Warranty gives you specific legal rights, and you may also have other rights which vary from state to state or from province to province.

**\*IMPORTANT: Carefully pack item to avoid damage in shipping. Be sure to include proof of purchase date and to attach tag to item before packing with your name, complete address and phone number with a note giving purchase information, model number and what you believe is the problem with the item. We recommend you insure the package (as damage in shipping is not covered by your Limited Warranty). Mark the outside of your package "ATTENTION CUSTOMER SERVICE".**

---

## Product Registration

Please visit [www.ninjakitchen.com](http://www.ninjakitchen.com) or call 1-877-646-5288 to register your new Ninja® product within ten (10) days of purchase. You will be asked to provide the store name, date of purchase and model number along with your name and address.

The registration will enable us to contact you in the unlikely event of a product safety notification. By registering you acknowledge to have read and understood the instructions for use, and warnings set forth in the accompanying instructions.



SharkNinja Operating LLC  
US: Newton, MA 02459  
CAN: Ville St-Laurent, QC H4S 1A7  
**1-877-646-5288**  
**ninjakitchen.com**

**Ninja** is a registered trademark of SharkNinja Operating LLC.  
**Storm** is a trademark of SharkNinja Operating LLC.

Illustrations may differ from actual product. We are constantly striving to improve our products, therefore the specifications contained herein are subject to change without notice.

For SharkNinja U.S. Patent information visit [sharkninja.com/USPatents](http://sharkninja.com/USPatents)

© 2016 SharkNinja Operating LLC  
QB751Q\_30\_SERIES\_IB\_160127\_1  
PRINTED IN CHINA