

**THANK YOU** for purchasing the Ninja THIRSTI™ Drink System



### REGISTER YOUR PURCHASE



registeryourninja.com



Scan QR code using mobile device

### RECORD THIS INFORMATION

Model Number: \_\_\_\_\_

Serial Number: \_\_\_\_\_

Date of Purchase: \_\_\_\_\_  
(Keep receipt)

Store of Purchase: \_\_\_\_\_

### TECHNICAL SPECIFICATIONS

Voltage: 120V-, 60Hz  
Power: 55 Watts

**SharkNinja Operating LLC**  
**US: Needham, MA 02494**  
**1-855-427-5130**  
**ninjakitchen.com**

Illustrations may differ from actual product. We are constantly striving to improve our products, therefore the specifications contained herein are subject to change without notice.

This product may be covered by one or more U.S. patents. See [sharkninja.com/patents](http://sharkninja.com/patents) for more information.

NINJA THIRSTI is a trademark of SharkNinja Operating LLC.

© 2023 SharkNinja Operating LLC.

WC1000\_Series\_IB\_MP\_Mv28



@ninjakitchen

# NINJA

## THIRSTI™ DRINK SYSTEM

WC1001 Series | Owner's Guide



# IMPORTANT SAFETY INSTRUCTIONS

PLEASE READ CAREFULLY BEFORE USE • FOR HOUSEHOLD USE ONLY



Read all instructions before using your Ninja Thirsti Drink System



Indicates the presence of a hazard that can cause personal injury, death or substantial property damage if the warning included with this symbol is ignored.



Avoid contact with hot surface. Always use hand protection to avoid burns.



For indoor and household use only.

## ⚠ WARNING

To reduce the risk of injury, fire, electrical shock or property damage, basic safety precautions must always be followed, including the following numbered warnings and subsequent instructions. Do not use appliance for other than intended use.

### General Precautions

- 1 To eliminate a choking hazard for young children, discard all packaging materials immediately upon unpacking.
- 2 Close supervision is needed when used by persons with reduced physical, sensory or mental capabilities or lack of experience and knowledge unless they have been given supervision or instruction concerning use of the appliance in a safe way and understand the hazards involved.
- 3 To reduce the risk of electric shock, this appliance has a polarized plug (one blade is wider than the other). As a safety feature, this plug will fit into a polarized outlet only one way. If the plug does not fit fully into the outlet, reverse the plug. If it still does not fit, contact a qualified electrician. **DO NOT** force into outlet or try to modify to fit.
- 4 Discontinue use if dropped from the countertop to the ground. Pressurized parts internal to the product present a risk of injury if damaged.
- 5 Keep the appliance and its cord out of reach of children. **DO NOT** let the power cord hang over the edge of counter.
- 6 **DO NOT** allow children to play with the appliance or be used by children under the age of 12.
- 7 To protect against fire, electric shock, and injury to persons, **DO NOT** immerse cord, plugs, or body of machine in water or other liquid.
- 8 To reduce the risk of injury from moving parts, unplug before servicing.
- 9 **NEVER** carry the appliance by the power cord or pull it to disconnect from electrical socket; instead grasp the plug and pull to disconnect.
- 10 **DO NOT** operate any appliance with a damaged cord or plug, or after the appliance malfunctions, or has been dropped or damaged in any manner. If damaged, contact SharkNinja Operating LLC for servicing.
- 11 For household and countertop use only. Only use your Ninja Thirsti Drink System in its upright position, on a flat, stable surface.
- 12 **DO NOT** place on or near a hot gas or electric burner, in a heated oven or on a stovetop.
- 13 **DO NOT** use in an appliance garage.
- 14 **DO NOT** unplug by pulling on the cord. To unplug, grasp the plug, not the cord. Unplug from outlet when appliance is not in use, and before cleaning.

# READ AND SAVE THESE INSTRUCTIONS

# IMPORTANT SAFETY INSTRUCTIONS

PLEASE READ CAREFULLY BEFORE USE • FOR HOUSEHOLD USE ONLY

## ⚠ WARNING

To reduce the risk of injury, fire, electrical shock or property damage, basic safety precautions must always be followed, including the following numbered warnings and subsequent instructions. Do not use appliance for other than intended use.

- 15 DO NOT** use an extension cord. A short power supply cord is used to reduce the risk of children grabbing the cord or become entangled in it, and to reduce the risk of people tripping over a longer cord.
- 16** Only use Ninja Thirsti Drink System in upright position, on a flat, stable surface.
- 17** Do not place on a hot surface (e.g. kitchen oven/stove) and never use it close to a flame or leave in direct sunlight.

### Operating Notice

- 1 DO NOT** use this appliance for anything other than its intended use.
- 2 ALWAYS** use appliance on a clean, dry, level surface.
- 3 DO NOT** operate without the CO<sub>2</sub> canister and the water reservoir installed.
- 4** Hand-tighten the CO<sub>2</sub> canister to ensure it is fully installed.
- 5 DO NOT** fill water reservoir with anything other than non-carbonated water. Other liquids will damage the product and present additional safety risks and injury.
- 6 DO NOT** overfill the water reservoir. Fill water only to the Fill Lines.
- 7 ALWAYS** place a vessel on the drip tray when dispensing water.
- 8 DO NOT** open the Flavor Carriage or move the unit during a cycle process.
- 9 DO NOT** use outdoors.
- 10 DO NOT** leave in direct sunlight.

### Flavor Drops

- Only use flavor drops intended for this appliance. **DO NOT** force them into the appliance.
- DO NOT** put Flavored Water Drops in the refrigerator.
- Flavor Pods should be disposed of 30 days after being opened.
- ALWAYS** dilute Flavored Water Drops through machine. Flavored Water Drops are concentrated flavor, **DO NOT** consume as drops.
- Ninja Thirsti Energy Flavor Drops are intended for adult use. Consume caffeine in moderation. consult your doctor if pregnant, nursing, or sensitive to caffeine.

### Water Reservoir

- 1 DO NOT** fill water reservoir with anything other than non-carbonated plain water, as other liquids will damage the product and present additional safety risks and injury.
- 2 DO NOT** leave water reservoir in a hot vehicle.
- 3 DO NOT** use the water reservoir to store food.
- 4 DO NOT** place water reservoir in freezer.
- 5 USE ONLY** filtered or drinking-quality water in this system.

### Carbon Dioxide CO<sub>2</sub> Canister

- Contents under pressure: May explode if heated. Keep out of direct sunlight and **DO NOT** expose the CO<sub>2</sub> Canister to heat above 120°F/50°C. Store in a well-ventilated area. **DO NOT** remove a CO<sub>2</sub> Canister from the product when it is being operated.
- DO NOT** use if wrap, seal, or valve appears to be damaged or tampered with. Inspect the CO<sub>2</sub> Canister and CO<sub>2</sub> Canister valve prior to use for dents, punctures, or other damage. If damaged, contact [ninjakitchen.com/support](http://ninjakitchen.com/support).
- To reduce the risk of a CO<sub>2</sub> leak, **ONLY** hand-tighten the CO<sub>2</sub> canister. **DO NOT** use tools. This can damage the product and the O-ring or CO<sub>2</sub> Canister. This may result in an uncontrolled flow of CO<sub>2</sub> gas, causing the product to over pressurize and result in personal injury or property damage.
- DO NOT** tamper with the CO<sub>2</sub> Canister in any way, including puncturing, incinerating, or removing the valve.
- DO NOT** handle or remove a CO<sub>2</sub> Canister while it is discharging CO<sub>2</sub>.
- In the event of a CO<sub>2</sub> leak, ventilate the area, breathe fresh air and if feeling unwell seek immediate medical attention.

# IMPORTANT SAFETY INSTRUCTIONS

PLEASE READ CAREFULLY BEFORE USE • FOR HOUSEHOLD USE ONLY

### Care & Maintenance

- 1 DO NOT** clean product with abrasive cleaners, steel wool pads, or other abrasive materials.
- Unplug before removing any parts and before cleaning.
- To prevent illness from bacterial growth in the appliance, follow all cleaning instructions in the Cleaning & Maintenance section of this Owner's Guide.
- Clean the system once a month and before storage.
- If the product is not operating properly, visit [ninjakitchen.com](http://ninjakitchen.com) or contact SharkNinja Operating LLC for examination, repair, or adjustment.
- Cleaning and user maintenance shall not be made by children.
- Immediately clean any spills or drips with cold water and soap.

## READ AND SAVE THESE INSTRUCTIONS

### PARTS

- A Drink System
- B Control Panel
- C Flavor Carriage
- D Mixing Chamber
- E Flavored Water Drops
- F CO<sub>2</sub> Door
- G CO<sub>2</sub> Canister
- H CO<sub>2</sub> Cover
- I Water Reservoir Dock
- J Water Reservoir
- K Removeable Cold Water Indicator
- L Hinging Cup Tray
- M Drip Tray Bucket

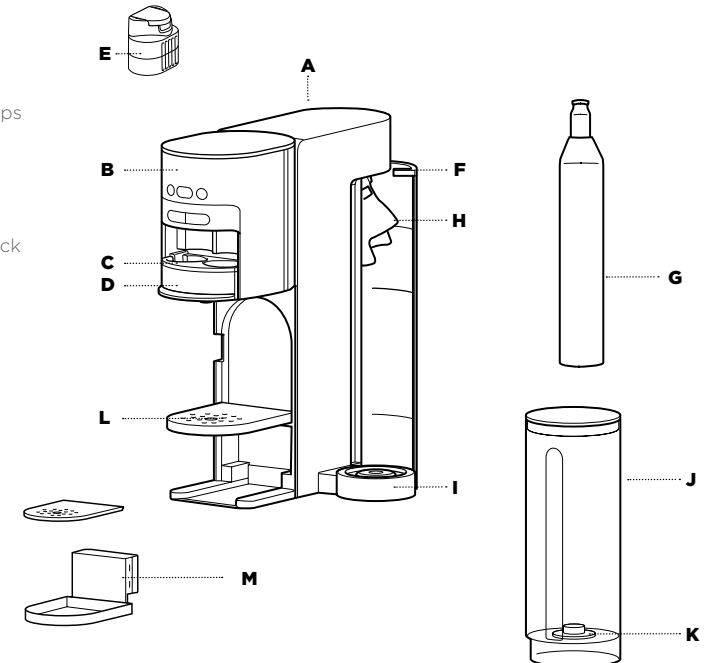

NOTE: Functions vary by model.

## PREPARING FOR FIRST USE



### BEFORE FIRST USE

- 1 Remove and discard any packaging material, stickers, and tape from the unit.
- 2 Pay particular attention to operational instructions, warnings, and important safeguards to avoid any injury or property damage.
- 3 **NEVER** put the Ninja Thirsti base unit in the dishwasher.

**NOTE: ONLY** carbonate still water.

- 4 Place the Ninja Thirsti base unit on a stable, flat surface and plug in.

### RINSE CYCLE

- 1 Place 12oz. cup on the hinged cup tray or bottom drip tray.
- 2 Fill the water reservoir with cold filtered water and place Water Reservoir docking station.
- 3 Select STILL by toggling the  button until the light below "Still" is illuminated.
- 4 Press the  button to select 12oz. dispense size.
- 5 Ensure Mixing Chamber is installed into Flavor Carriage and in raised position.
- 6 Press the "Start" button to start the Rinse Cycle.
- 7 Dispose of the dispensed water once the Rinse Cycle is complete.

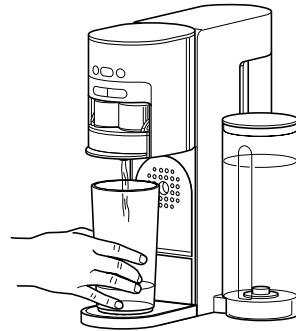

## SETTING UP YOUR NINJA THIRSTI DRINK SYSTEM

### SETTING UP NINJA THIRSTI DRINK SYSTEM

Scan here to watch a video on setting up your Ninja Thirsti Drink System.



### INSTALLING CO<sub>2</sub> CANISTER

- 1 Open the CO<sub>2</sub> door at the back of the unit.

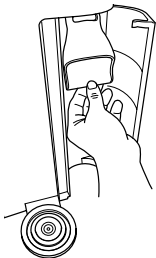

- 2 Swing the CO<sub>2</sub> cover out of the unit.
- 3 Insert the CO<sub>2</sub> canister into the CO<sub>2</sub> cover. Applying gentle pressure, turn to the right until tight.

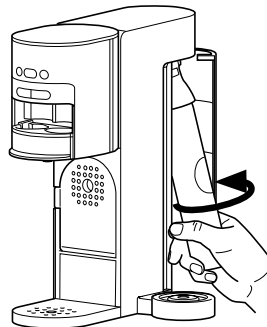

- 4 Press CO<sub>2</sub> canister into unit. Close the door.

## SETTING UP YOUR NINJA THIRSTI DRINK SYSTEM CONT.

### HOW DO I KNOW CO<sub>2</sub> IS PROPERLY INSTALLED?

- 1 Canister cannot be turned anymore.
- 2 Carbonation is present in Sparkling drinks.
- 3 There is no hissing sound from the back of the unit when making a sparkling drink.

### PREPARE WATER RESERVOIR

- 1 Fill water reservoir with ice and cold, filtered water.
 

**TIP:** Filtered water guarantees a clean, clear taste.
- 2 Place water reservoir on the Water Reservoir dock. Measurement gradients should face forward when properly installed.

**NOTE:** Check the Cold Water Indicator at the bottom of the reservoir. The brighter the blue, the colder the water, the fizzier the drink.

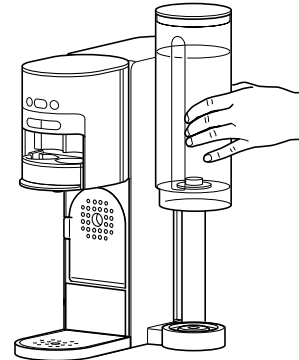

**TIP:** Store Water Reservoir in fridge when not in use.

### INSTALLING THIRSTI FLAVORED WATER DROPS

Flavored Water Drops Bottles are designed to be interchangeable between drinks for endless drink customization.

### INSTALL

- 1 Remove safety seal.



- 2 Flip the cap into the open position. The cap will click into place on the backside of the Flavored Water Drops bottle.

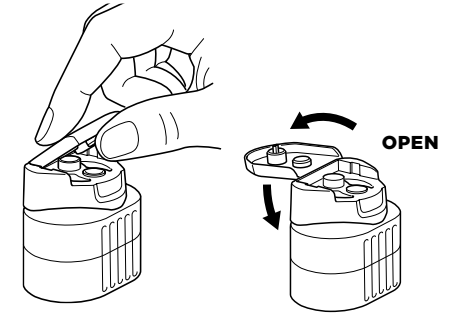

- 3 Lower the Flavor Carriage to open.

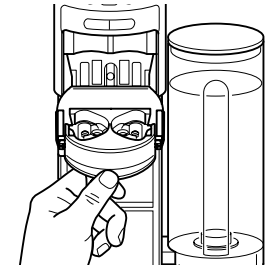

- 4 Flip the Flavored Water Drops so the nozzle is down and gently insert it into the Flavor Carriage. An audible click indicates proper installation.

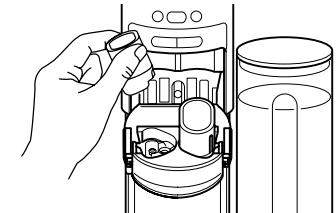

- 5 Repeat with a second Flavored Water Drops bottle if a combo beverage is desired.
- 6 Raise the Flavor Carriage to close.

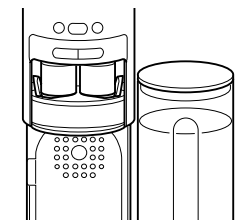

## SETTING UP YOUR NINJA THIRSTI DRINK SYSTEM CONT.

### REMOVING THIRSTI FLAVORED WATER DROPS

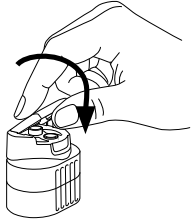

- 1 Lower the Flavor Carriage to open.
- 2 Remove the Flavored Water Drops and snap cap into the closed position.



**NOTE:** Flavor drops have a shelf life of 30 days once opened.

**NOTE:** It is recommended to store Flavored Water Drops in a cool, dark place to further maintain aroma, color and taste.

### CO<sub>2</sub> LOW WARNING

When the  button turns orange there is approximately 25% CO<sub>2</sub> remaining, or enough for approximately 25 12oz. drinks. The  button will remain orange until a new CO<sub>2</sub> canister is installed and the indicator is reset.

Once a new CO<sub>2</sub> canister has been installed, reset the indicator by pressing and holding the  button for 3 seconds or until it turns from orange to white.

**NOTE:** Only reset the indicator when a new canister has been installed.

**NOTE:** Only use Ninja Thirsti CO<sub>2</sub> Canisters for best carbonation results.

### REPLACING CO<sub>2</sub> CANISTER

- 1 Open the CO<sub>2</sub> door at the back of the unit and swing out the CO<sub>2</sub> canister.
- 2 Slowly twist the CO<sub>2</sub> canister to the left until it releases from the unit.
- 3 Follow the installation directions to install a new CO<sub>2</sub> canister.
- 4 Press and hold the  button for 3 seconds. When the button illuminates white or a beep is heard, the CO<sub>2</sub> has been reset to accurately notify when carbonation is running low.

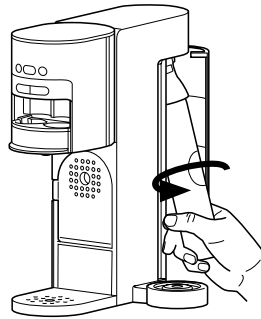

## USING THE CONTROL PANEL

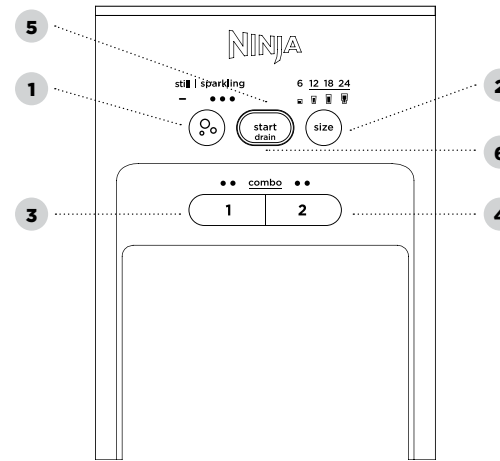





- 1 Sparkling Strength Button  
\*Number of Sparkling levels will vary by model
- 2 Size Button
- 3 Flavor 1 Strength Button
- 4 Flavor 2 Strength Button
- 5 Start Button
- 6 Drain  
When drain is blinking, press "Start" to proceed

## USING YOUR NINJA THIRSTI DRINK SYSTEM

### SETUP CHECKLIST

- 1 Ninja Thirsti Drink System is plugged in.
- 2 CO<sub>2</sub> is tightly installed.
- 3 The reservoir is filled with cold water and placed on the docking station.
- 4 Desired Flavored Water Drops are installed.

### GET STARTED DRINK MAKING

- 1 Press  button to toggle between Low, Medium, or High Sparkling.
- 2 Press  button to select 6oz., 12oz., 18oz., or 24oz. dispense volume.
- 3 Press the  button or  button to toggle through No Flavor (0 LEDs illuminated), Classic Flavor (1 LED illuminated), and Bold Flavor (2 LEDs illuminated) strengths.
- 4 Press  button to start drink making.
- 5 The Beverage Dispense Light will turn on while the beverage is dispensing. Once the beverage is complete, the light will turn off and an audible end tone will be heard.

**NOTE:** Combining two flavors is **NOT** available when 6oz. dispense size is selected.

**NOTE:** Always empty the Drip Tray Bucket before, or as soon as the orange full indicator appears.

# THIRSTI FLAVOR POD NUTRITION AND DOSING

## THIRSTI FLAVOR POD DOSING CHARTS

**NOTE:** When making a combo drink with two different Flavored Water Drops, each flavor will dose at 50% ensuring the perfect combo drink every time. When boosting flavor from Classic strength (single LED) to High strength (two LEDs), flavor dispense increases by 40%.

| SPLASH FLAVOR DOSING (mL)* |     |     |      |     |
|----------------------------|-----|-----|------|-----|
| Sizes (oz)                 | 6   | 12  | 18   | 24  |
| Single (Classic Strength)  | 1.8 | 3   | 4.5  | 6   |
| Single (High Strength)     | 2.5 | 4.2 | 6.3  | 8.4 |
| Combos (Classic Strength)  | —   | 1.8 | 2.25 | 3   |
| Combos (High Strength)     | —   | 2.1 | 3.2  | 4.2 |

| HYDRATION FLAVOR DOSING (mL)* |     |     |     |      |
|-------------------------------|-----|-----|-----|------|
| Sizes (oz)                    | 6   | 12  | 18  | 24   |
| Single (Classic Strength)     | 1.8 | 3.6 | 5.4 | 7.2  |
| Single (High Strength)        | 2.5 | 5.0 | 7.6 | 10.1 |
| Combos (Classic Strength)     | —   | 1.8 | 2.7 | 3.6  |
| Combos (High Strength)        | —   | 2.5 | 3.8 | 5.0  |

| VITAMIN (B) FLAVOR DOSING (% DV)* |    |     |       |     |
|-----------------------------------|----|-----|-------|-----|
| Sizes (oz)                        | 6  | 12  | 18    | 24  |
| Single (Classic Strength)         | 5% | 10% | 15%   | 20% |
| Single (High Strength)            | 7% | 14% | 21%   | 28% |
| Combos (Classic Strength)         | —  | 5%  | 7.5%  | 10% |
| Combos (High Strength)            | —  | 7%  | 10.5% | 14% |

| ENERGY FLAVOR DOSING (Mg CAFFEINE)* |      |      |       |       |
|-------------------------------------|------|------|-------|-------|
| Sizes (oz)                          | 6    | 12   | 18    | 24    |
| Single (Classic Strength)           | 25.0 | 50.0 | 75.0  | 100.0 |
| Single (High Strength)              | 35.0 | 70.0 | 105.0 | 140.0 |
| Combos (Classic Strength)           | —    | 25   | 37.5  | 50    |
| Combos (High Strength)              | —    | 33.3 | 50.0  | 66.7  |

**\*DISCLAIMER:** The above tables are target dosing and may change depending on unit variation.

# CLEANING & MAINTENANCE

## DISHWASHER-SAFE PARTS

Drip Tray and Drip Tray bucket are top-rack dishwasher safe.

## CLEANING WATER RESERVOIR

Empty the reservoir and remove the cold water indicator. Clean with warm, soapy water. To clean more thoroughly, use a soft foam brush.

## CLEANING FLAVOR FUNNEL

Remove the flavor funnel and clean with warm soap and water as needed.

## CLEANING FLAVOR CARRIAGE

To clean the flavor carriage, use a damp towel and wipe gently. We recommend monthly cleaning.

## CLEAN CYCLE

is recommended to run a Clean Cycle on your Ninja Thirsti Drink System every month or before storage.

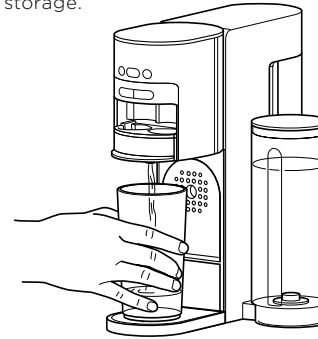

- 1 Create a cleaning solution by combining 12oz. of water and 12oz. of white vinegar in the water reservoir.
- 2 Place the water reservoir with the cleaning solution on the docking station.
- 3 Place a large (24oz.) vessel on the drip tray.
- 4 To start the Clean Cycle, simultaneously hold down the button and button for 3 seconds.
- 5 Once the Clean Cycle is complete, empty any leftover cleaning solution and rinse the water reservoir.

**NOTE:** The clean cycle could take up to 15 minutes.

- 6 Refill the water reservoir with 24oz. of fresh water and repeat the clean cycle to flush the vinegar from the unit.

**IMPORTANT: DO NOT** remove the 24oz. vessel at any time during the clean cycle.

## CO<sub>2</sub> CANISTER EXCHANGE



Scan the QR code below and sign up for the Thirsti CO<sub>2</sub> Refill Club to never run out of bubbles!

## EXPLORE 20+ FLAVORS ACROSS MULTIPLE FLAVOR LINES!



Try new flavors and reorder your favorites by scanning the QR code below!

## ACCESSORIES



Shop Thirsti Drink System Replenishment and Accessories!



Ninja Thirsti 60L CO<sub>2</sub> Canister

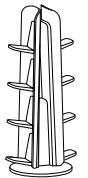

Ninja Thirsti 360- Flavor Drops Storage



Ninja Thirsti Travel Bottle



Ninja Thirsti Flavored Water Drops



Ninja Thirsti 48oz. Water Reservoir

## HELPFUL TIPS

### SYSTEM TIPS

- **NEVER** put the water reservoir or Flavored Water Drops in the freezer.
- **ALWAYS** store water reservoir in the refrigerator for cold, ready-to-carbonate water.
- Set your refrigerator to 37°F to ensure water will reach optimally cold temperature.
- **ALWAYS** empty the drip tray before or as soon as the orange “full” indicator is visible.

### BEVERAGE MAKING TIPS

- The colder the water, the greater the carbonation.
- Higher carbonation enhances the sweetness of the Flavored Water Drops.
- Each 60L CO<sub>2</sub> Canister will make 50-100 12oz. drinks depending on level of carbonation.

## TROUBLESHOOTING GUIDE



### HOW DO I TURN MY THIRSTI DRINK SYSTEM OFF?

- The Thirsti Drink System will enter a sleep mode after 10 minutes of no use. To wake the system, press any button.
- To completely shut down the Thirsti Drink system, unplug the unit.

### WHY IS MY UNIT NOT CARBONATING?

- Ensure CO<sub>2</sub> canister is fully installed inside the CO<sub>2</sub> door. If canister can still turn to the right, continue to twist until it can no longer turn.
- Reminder to only use Ninja Thirsti CO<sub>2</sub> canisters as other screw in style canisters might not be compatible.

### HOW DO I ENTER ULTRA LOW SPARKLING MODE?

- Use Ultra Low Carbonation to make a very lightly carbonated drink. To initiate Ultra Low sparkling, hold down the  button +  button. A single Sparkling LED will blink to confirm Ultra Low Sparkling state has been entered. Ultra Low Sparkling will turn off when another Sparkling level is chosen or the unit is unplugged and plugged back in.

### WHY IS THE BUTTON ORANGE?

- The Sparkling button turns orange to indicate low CO<sub>2</sub>. When the button turns orange, there is enough CO<sub>2</sub> for approximately 25 12oz. drinks.
- After installing a new canister, reference pg. 5 for instructions on resetting the CO<sub>2</sub> Low indicator.

### DID YOU END YOUR CYCLE BY PRESSING START?

- If you pressed the start button during a cycle the product will prompt you to drain. See below for instruction on completing a Drain Dispense.

### WHY IS “DRAIN” SHOWING ON MY UNIT?

- If the last dispense cycle was interrupted, then water must be drained from the unit. Place a cup under the nozzle and press the start button to allow a Drain Dispense to complete. The unit must run a Drain Dispense before another drink can be made. Always empty the Drip Tray Bucket before, or as soon as the orange full indicator appears.

### WHY WON'T MY UNIT RUN?

- Check that the Mixing Chamber is installed into the Flavor Carriage and in the raised position.
- Ensure the unit is plugged into a working outlet. The display panel will illuminate when power is detected.
- Ensure water has been added to the water reservoir and there is no blockage on the docking station.

### WHY CAN'T I MAKE A COMBO DRINK ON 6OZ?

- The combo function is only available when a 12oz., 18oz., or 24oz. size is selected.

### BEVERAGE DISPLAY LIGHT IS BLINKING.

- An error has occurred. Unplug the unit and reseal the water reservoir, ensuring it is filled. Wait 30 seconds before plugging back in. If the issue persists, contact Ninja Customer Support.

### NO OR LOW FLAVOR IN DRINK.

- Remove Flavored Water Drops from Flavor Carriage and ensure that it is not empty. When empty, the Flavored Water Drops bottle will feel light and have a minimal amount of flavor left inside.
- Install the Flavored Water Drops into the Flavor Carriage, ensuring it is seated completely and the Mixing Chamber is in the raised position. Set corresponding flavor strength on the display panel to Classic or High strength.

### WHY IS WATER SPLATTERING?

- Some splatter is normal. Use the cup tray, when possible, to reduce the distance between the cup and the dispense outlet.

### WHY DOES MY SYSTEM FLASH DIFFERENT COLORS WHEN I OPEN THE FLAVOR CARRIAGE?

- The Ninja Thirsti features innovative flavor line detection. The flashing occurs to signify to the machine to dispense the correct amount of fluid based on the type of Flavor Water Drops installed.

### QUESTIONS?

- 1-855-427-5130

# Shark | NINJA

## ONE (1) YEAR LIMITED WARRANTY

NJA\_1\_YR\_IB\_LMTD\_WRNTY\_US\_ENG\_BEVERAGE

The One (1) Year Limited Warranty applies to purchases made from authorized retailers of **SharkNinja Operating LLC**. Warranty coverage applies to the original owner and to the original product only and is not transferable.

SharkNinja warrants that the unit shall be free from defects in material and workmanship for a period of one (1) year from the date of purchase when it is used under normal household conditions and maintained according to the requirements outlined in the Owner's Guide, subject to the following conditions and exclusions:

### What is covered by this warranty?

1. The original unit and/or non-wearable parts deemed defective, in SharkNinja's sole discretion, will be repaired or replaced up to one (1) year from the original purchase date.
2. In the event a replacement unit is issued, the warranty coverage ends six (6) months following the receipt date of the replacement unit or the remainder of the existing warranty, whichever is later. SharkNinja reserves the right to replace the unit with one of equal or greater value.

### What is not covered by this warranty?

1. Normal wear and tear of wearable parts (such as blending vessels, lids, cups, blades, blender bases, removable pots, racks, pans, etc.), which require regular maintenance and/or replacement to ensure the proper functioning of your unit, are not covered by this warranty. Replacement parts are available for purchase at [ninjaaccessories.com](http://ninjaaccessories.com).
2. Any unit that has been tampered with or used for commercial purposes.
3. Damage caused by misuse, abuse, negligent handling, failure to perform required maintenance (e.g., failure to keep the well of the motor base clear of food spills and other debris), or damage due to mishandling in transit.
4. Consequential and incidental damages.
5. Defects caused by repair persons not authorized by SharkNinja. These defects include damages caused in the process of shipping, altering, or repairing the SharkNinja product (or any of its parts) when the repair is performed by a repair person not authorized by SharkNinja.
6. Products purchased, used, or operated outside North America.

### How to get service

If your appliance fails to operate properly while in use under normal household conditions within the warranty period, visit [ninjakitchen.com/support](http://ninjakitchen.com/support) for product care and maintenance self-help. Our Customer Service Specialists are also available at **1-855-427-5130** to assist with product support and warranty service options, including the possibility of upgrading to our VIP warranty service options for select product categories. So we may better assist you, please register your product online at [registeryourninja.com](http://registeryourninja.com) and have the product on hand when you call.

SharkNinja will cover the cost for the customer to send in the unit to us for repair or replacement. A fee of \$20.95 (subject to change) will be charged when SharkNinja ships the repaired or replacement unit.

### How to initiate a warranty claim

You must call **1-855-427-5130** to initiate a warranty claim. You will need the receipt as proof of purchase. We also ask that you register your product online at [registeryourninja.com](http://registeryourninja.com) and have the product on hand when you call, so we may better assist you. A Customer Service Specialist will provide you with return and packing instruction information.

### How state law applies

This warranty gives you specific legal rights, and you also may have other rights that vary from state to state. Some states do not permit the exclusion or limitation of incidental or consequential damages, so the above may not apply to you.